

AS A263 is Asteknik's patented profile (Patent No: TR 2010 06287B) and designed for extreme heavy duty use. Thanks to arch shape which lets it to resist to more load than other flush mounted heavy duty profiles and secures a smooth transition for the vehicles. Pure metal structure characterizes AS A263 to be a hardwearing and maintenance free profile. Hinged & sliding profile design enables to meet the displacements in 3 directions. EPDM cords placed between side frames and center plate eliminate metal stroking noise. For superiorly installation, AS A263 can be assembled by means of special aluminum anchorages. Profiles are delivered factory-assembled.

- Application Areas** : Indoor & Outdoor / Floor
- Ideal for** : Factories, Warehouses, Car Parks, Airports, Shopping Malls etc.
- Material** : Mill Finish Aluminum (Anodizing optional), EPDM Cord
- Aluminum Alloy** : 6063 AA-USA / EN AW 6063
- Optional Supplies** : Fire Barrier, Waterproof EPDM membrane

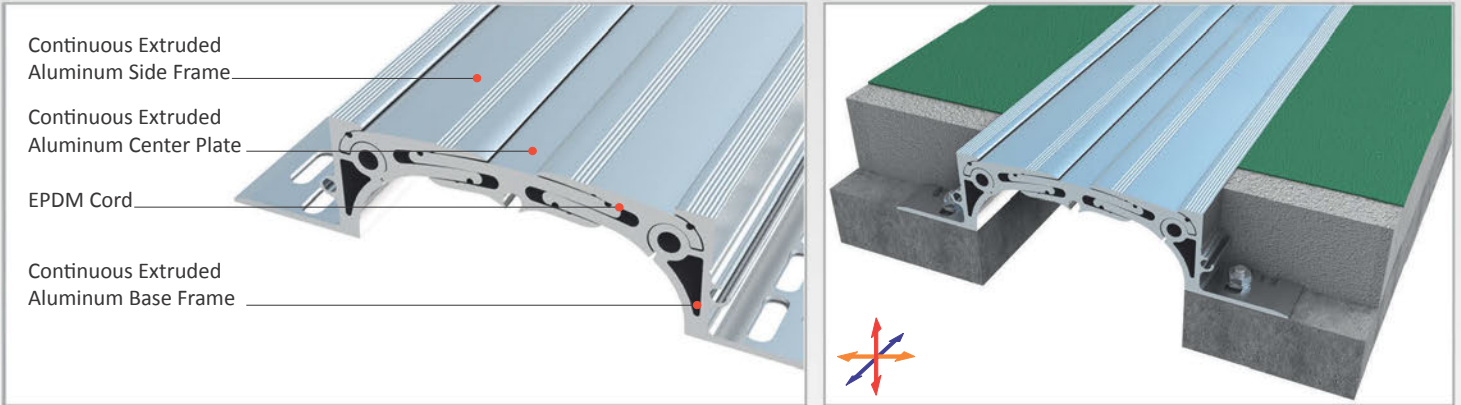

FLOOR

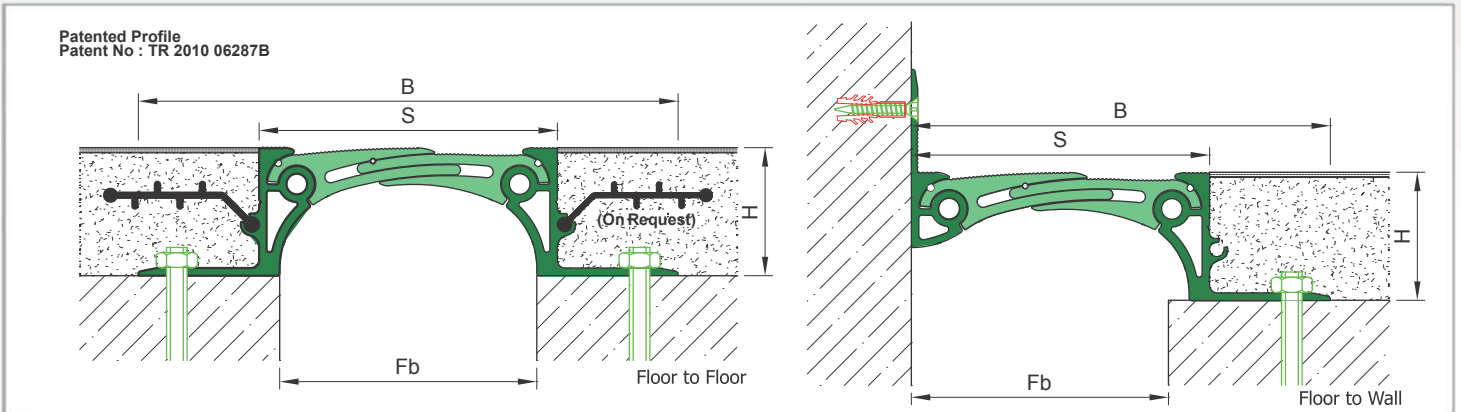



* Visuals are representative and the profile configuration may differ depending on the characteristics requested.

| LOCATION | MODEL | GAP (Fb) mm | HEIGHT (H) MM | OVERALL WIDTH (B) mm | VISIBLE WIDTH (S) mm | MOVEMENT (W) mm | LOAD CAPACITY | STANDARD LENGTH (mt) |
|----------------|-------------|-------------|---------------|----------------------|----------------------|-----------------|---------------|----------------------|
| Floor to Floor | AS A263-080 | 80 | 50 | 194 | 100 | ± 12 | 70 kN 600 kN | 3 |
| | AS A263-100 | 100 | 50 | 210 | 116 | ± 12 | 70 kN 600 kN | 3 |
| | AS A263-120 | 120 | 50 | 234 | 140 | +22 / -12 | 35 kN 300 kN | 3 |
| | AS A263-150 | 150 | 50 | 250 | 166 | ± 22 | 25 kN 120 kN | 3 |
| | AS A263-200 | 200 | 50 | 332 | 218 | ± 25 | | 3 |

Note: Please ask for different sizes

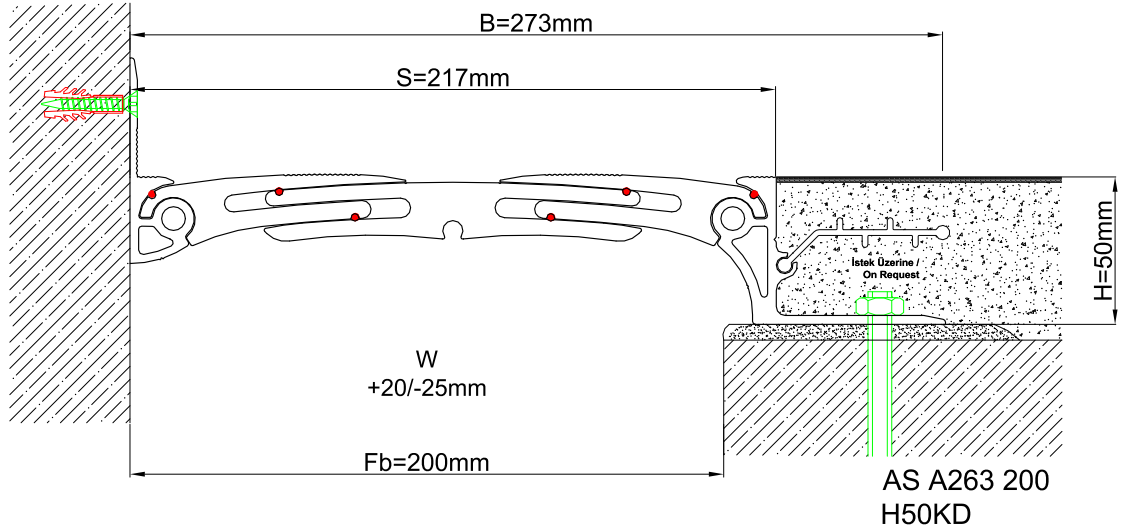
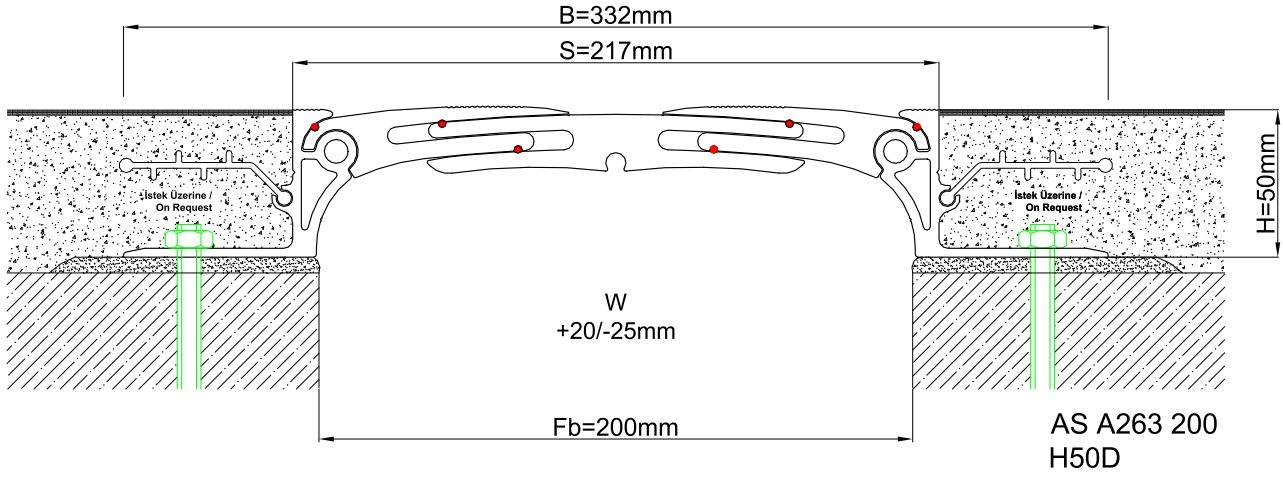
Patent No : TR 2010 06287B
Patentli Profildir / Patented Profile



| Profil No Profile Number | AS A263 200 | AS A263 200K |
|---|---|--------------|
| Fb (mm) | 200 | 200 |
| H (mm) yaklaşık approx. | 50 | 50 |
| W± (mm) yaklaşık approx. | +20/-25 | +20/-25 |
| Renk Color | Alüminyum: Natürel Aluminum: Natural | |
| Malzeme Material | Alüminyum Aluminum | |
| Standart Uzunluk (m) Standard Length (m) | 3 | |
| Yükleme Kapasitesi Load - Bearing Capacity |  | |